

**City of Goodlettsville
Board of Zoning and Sign Appeals
MEETING AGENDA**

Tuesday October 1, 2024

5:00 PM

GOODLETTSVILLE CITY HALL - MASSIE CHAMBERS

Approval of September 3, 2024 Meeting Minutes

(PUBLIC HEARINGS)

ITEM#1 Liz Young, Property Owner Representative: Requests accessory building location variance at 980 Hitt Lane. The 5.21-acre property referenced as Davidson County Tax Map/Parcel# 02500008300 is zoned Agricultural. Zoning Ordinance Sections: 14-208 (1)(c) and 14-208 (1)(e). Property Owners: Heather and Stephen Connors

- Staff Presentation
- Applicant Presentation
- Public Hearing Public Comments
- Board Discussion and Motion

ITEM#2 Boom Sign and Lighting: Requests electronic signage variance for a proposed Jubilee Hills sign on Conference Drive. The 0.98- acre property referenced as Davidson County Tax Map/Parcel# 02600017100 Zoning Ordinance Sections: 14-305 (1) (c) Property Owner: A.P. Development Properties, INC

- Staff Presentation
- Applicant Presentation
- Public Hearing Public Comments
- Board Discussion and Motion

*A government committed to operating with efficiency and integrity in all we do
as we strive to enhance the quality of life for the community we serve.*

105 S. Main Street – Goodlettsville, TN 37072 – 615-851-2202

www.goodlettsville.gov

OFFICIAL MINUTES OF THE MEETING

GOODLETTSVILLE BOARD OF ZONING AND SIGN APPEALS

September 3, 2024

Goodlettsville City Hall

5:00 p.m.

Massie Chambers-Auditorium

Present: Chairman Brian Rager, Commissioner Stuart Huffman, and Larry Jones.

Absent: Commissioner Jimmy D. Anderson and Mark Writesman.

Also Present: Addam McCormick (Staff), Tim Ellis-City Manager, Russell Freeman-City Attorney, Jenni Lester (Staff), and Sharon Reed (Staff).

Chairman Brian Rager called the meeting to order at 5:00 pm and declared a quorum.

Approval of August 6, 2024 Meeting Minutes: Huffman made a motion to approve the minutes of the August 6, 2024 meeting, Jones seconded the motion. Motion was approved.

AGENDA

Item #1 Eric Fishman, MD/ Property Owner Representative: Requests conditional use approval for a bed and breakfast homestay use at 1357 Madison Creek Road. The 21.9-acre property referenced as Sumner County Tax Map/Parcel# 14002205000 is zoned R-40, Low Density Residential. Zoning Ordinance Sections: 14-205 (3)(c) and 14-213 (9)(h)(ii). Property Owner: Qualia 17 Irrevocable Trust.

Staff Discussion:

- The 21.9-acre property is zoned R-40, Low Density Residential.
- Due to acreage of the property being over five (5) acres, the Zoning Ordinance permits through the conditional use review process a bed and breakfast homestay use in the R-40 zoning district.
- The Board's conditional use review criteria include both the general and specific bed and breakfast homestay provisions.
- The Board can include reasonable conditions with any motion based on the general and specific conditional use provisions.
- The applicant will need to present the proposed bed and breakfast homestay operation for the Board to determine if the proposed operation meets the general and specific conditional use review criteria.
- Staff presented Zoning Ordinance Sections: 14-213 (9)(c) Requirements for conditional use permit and 14-213 (9)(h)(ii) Bed and Breakfast homestay.
- Motion Option-To approve the conditional use request based on the request meeting the referenced Zoning Ordinance conditional use general and specific review criteria as determined by the Board during the meeting.
- Motion Option-To deny the conditional use request based on the request not meeting the referenced Zoning Ordinance conditional use general and specific review criteria as determined by the Board during the meeting.
- Motion Option-To defer the request for the applicant to provide additional information as determined by the Board during the meeting. (Applicant's Request/Staff Recommendation)

Applicant: Not Present

Rager opened the Public Hearing for Citizen Comments:

Brooke Eakes – 3330 Patton Branch Road and 1352 Madison Creek Road

Ms. Eakes owns property on the back side and across the street from this location and is opposed to the Bed and Breakfast. Ms. Eakes states that her grandmother lives across the street from the property and wants to know who her neighbors are. Ms. Eakes states when this was an Airbnb there were a lot of cars in and out and if this becomes a Bed and Breakfast there will be a lot of strange cars they do not know in and out of the property. Ms. Eakes stated that if this one is approved there will be others coming forward for consideration. Ms. Eakes stated she did not want to see a sign for a Bed and Breakfast outside her front door for this address.

Millard Kizer, Jr. – 1356 Madison Creek Road

Mr. Kizer lives across the street from this property and wants to know how many times the police are called before this is a public nuisance. Mr. Kizer stated his biggest concern is public nuisance. Mr. Kizer has observed people coming out there not knowing where they are going and turnaround in other driveways trying to find the place. Mr. Kizer would like to know what it takes to violate public nuisance and close it down.

Mr. Ellis responded to Mr. Kizer’s comments regarding public nuisance. Mr. Ellis stated that there is a process that public nuisance would go through the Sumner County District Attorney and Circuit Court.

No additional citizen comments.

The Public Hearing was closed.

Board Discussion:

- Huffman asked McCormick if the information they received from a previous meeting was correct and the owner lived in Florida?
- McCormick responded yes and from his understanding he is looking for a strategy to rent for longer term and have the option to come back in town to operate as a bed and breakfast and he would reside at the residence.

Motion: Huffman made a motion to defer the request, seconded by Jones. The motion passed.

Item #2 Shailee Fisher/Property Representative: Requests conditional use approval for an entertainment and amusement use for an indoor baseball batting facility at 910 Rivergate Parkway. The 0.8-acre property referenced as Davidson County Tax Map/Parcel# 03402006400 is zoned CSL, Commercial Services Limited. Zoning Ordinance Sections: 14-206 (3)(c) and 14-213 (9)(f)(ii). Property Owner: Norman Clark Limited Partnership.

Staff Discussion:

- The property is zoned CSL, Commercial Services Limited.
- The CSL zoning district permits the entertainment and amusement services use through the conditional use review process.
- The Board’s conditional use review criteria include the general conditional use provisions and one specific entertainment and amusement use provision.
- Staff’s interpretation is the specific entertainment and amusement use provision regarding batting cages would not apply for the proposed building interior only request.
- The proposal does not include any exterior facilities which would be an issue in the CSL zoning district.
- The Board can include conditions with any motion based on the general conditional use provisions.
- The applicant will need to present the proposed indoor batting facility operation for the Board to determine if the proposed operation meets the general use review criteria.
- Staff presented Zoning Ordinance Sections: 14-213 (9)(c) Requirements for conditional use permit and 14-213 (9)(f)(ii).

- Motion Option-To approve the conditional use request based on the request meeting the referenced Zoning Ordinance conditional use general review criteria as determined by the Board during the meeting. (Staff Recommendation)
- Motion Option-To deny the conditional use request based on the request not meeting the referenced Zoning Ordinance conditional use general review criteria as determined by the Board during the meeting.
- Motion Option-To defer the request for the applicant to provide additional information as determined by the Board during the meeting.

Applicant: Shailee Fisher, Property Representative

- Ms. Fisher stated she has twin boys aged six (6) years old and they love, eat, and breathe baseball.
- Ms. Fisher stated the boys are always wanting to go play baseball so she and her husband decided to provide a facility not only for her boys but for all the athletes in the Goodlettsville community.
- Ms. Fisher feels this would be a safe environment for them to come and grow and develop as young individuals.
- Ms. Fisher stated this will be open to the public.
- Ms. Fisher stated everything will be inside and no exterior play.

Rager opened the Public Hearing for Citizen Comments:

Jeff Parnell – 19 Rolling Meadows

Mr. Parnell stated he supports this project and feels this will be good for the community and good use of this facility/property.

No additional citizen comments.

The Public Hearing was closed.

Board Discussion:

- Huffman asked Freeman for clarification on (ii) special conditions for entertainment and amusement services.
- Freeman responded and clarified the potential use all interior and confirmed no exterior facility at this location.
- Huffman commented he thinks this is a great project for the community and this property.

Motion: Huffman made a motion to approve based on the conditional use, seconded by Jones. The motion passed.

With no further business, Huffman made the motion to adjourn, seconded by Jones .

The meeting adjourned at 5:27 pm.

Brian Rager, Chairman

Sharon Reed, Planning Assistant

**City of Goodlettsville
Board of Zoning and Sign Appeals
STAFF REPORT**

Tuesday October 1, 2024

5:00 PM

GOODLETTSVILLE CITY HALL - MASSIE CHAMBERS

Approval of September 3, 2024 Meeting Minutes

MOTION OPTIONS:

1. Approve as listed
2. Approve with minute amendments as determined by the Board of Zoning and Sign Appeals

ITEM#1 **Liz Young, Property Owner Representative:** Requests accessory building location variance at 980 Hitt Lane. The 5.21-acre property referenced as Davidson County Tax Map/Parcel# 02500008300 is zoned Agricultural. Zoning Ordinance Sections: 14-208 (1)(c) and 14-208 (1)(e). Property Owners: Heather and Stephen Connors

AGENDA ITEM REVIEW PROCESS:

- Staff Presentation
- Applicant Presentation
- Public Hearing** Public Comments
- Board Discussion and Motion

STAFF NOTES:

Per variance application:

We are requesting to rebuild a detached garage for our customer however in front of the front line of the house as we cannot build behind due to a hill and wall behind that would be too costly to cut out to make flat to build.

The 5.21-acre property at 980 Hitt Lane is zoned Agricultural. The proposal is for a replacement accessory building beside and in front of the house (primary structure) on the property. The proposal is for a twenty (20') x forty (40') feet-800 square feet building. The request is based on the property slopes behind the house ranging from 590' to 630' feet for roughly 110' feet back from the front of the house on the property. The property contains thirty-five (35%+) plus percent slopes in this area. An approved variance would need to include the stipulation that no accessory building would be permitted to be constructed within sixty (60') of the top of stream bank along the front of the property. The house is roughly

200 feet from the front property line/ Hitt Lane right of way frontage. The request is for a metal pole barn type structure. Due to the proposed location of the building beside and in front of the house, the City's Zoning Ordinance material consistency requirement exemption for accessory buildings over 504 square foot in Agricultural zoning district and on properties over five (5) acres would not apply. The requested variances are for the location of the proposed replacement accessory building beside and in front of the house due to the property slopes and a material consistency requirement exemption.

MOTION OPTIONS:

1. Motion to approve the variance request with the listed staff stipulation based on the request meeting the variance review criteria 14-213 (8) (c) (vi) due to the property topographical conditions with thirty-five (35%) percent plus slopes
2. Motion to deny the variance request based on the request not meeting the Zoning Ordinance variance review criteria as determined by the Board during the meeting
3. Motion to defer the request for the applicant to provide additional information as determined by the Board during the meeting

*Staff recommendation to be provided during meeting

Referenced Zoning Ordinance Sections:

(c) In all residential districts, except for residential planned unit development districts, no lots shall have erected thereon more than one principal building. Principal buildings and additions as well as additions in residential districts consisting of wall, roof, floor, and foundation connections shall meet the requirements of the applicable zoning district. Permitted limited connection additions in residential districts and accessory buildings in all districts shall meet the following requirements in items (d) and (e) and the requirements of the applicable zoning district.

To ensure order in site developments including building and lot bulk standards and the compatibility of buildings constructed on-site, all buildings and structures, additions and accessory buildings or structures in residential districts which exceed 504 square footage shall be constructed of roof and exterior wall materials consistent with the primary roof and exterior wall materials of the principal building or structure.

One accessory building or structure is permitted less than the 504 square footage requirements not meeting the primary building material consistency requirements of this section. Accessory buildings or structures permitted or installed per city requirements prior to the adoption of the material consistency requirement per

Ordinance 15-844 (September 10, 2015) would not be used in calculating the square footage permitted less than the 504 square footage permitted per property.

On primary roof and exterior wall materials of the principal large acreage agricultural and R-40 zoned properties consisting of five or more acres, accessory building(s) or structure are not required to be constructed of consistent materials of the primary building if the accessory building(s) or structure is constructed entirely behind and separate from the primary building and is constructed per the building setbacks of the zoning district.

The primary exterior wall and roof materials of the principal building shall be extended on all sides of the exterior walls and roof of additions or accessory buildings or structures. In the case of principal buildings or structures with multiple exterior wall materials, the addition and accessory building or structure may be constructed of materials at the same ratio of the principal building or structure. Alternative designs for large acreage properties as referenced above and alternative designs that exceed the purpose and intention of the items referenced above with single family and duplex residential building and structures may be approved by planning and development services staff. Staff's decision on alternative designs may be appealed to the planning commission for review. All other building and structures shall meet site and architectural design standards and the Goodlettsville Design Guidelines.

14-208 (1)(e)

(e) Accessory buildings. No accessory building or structure shall be erected between a front lot line and a front wall of the principal building or structure.

In addition accessory buildings or structures shall:

- (i) Be customarily incidental to the principal use established on the same lot.
- (ii) Be subordinate to and serve such principal use.
- (iii) Be subordinate in area, intent, and purpose to such principal use.
- (iv) Contribute to the comfort, convenience, or necessity of users of such principal use.
- (v) Building or structure shall not exceed the height of the principal structure.
- (vi) No accessory use or building and structure shall be constructed or established on any lot prior to the time of construction of the principal structure to which it is accessory. This section shall not be construed to govern the sequencing or phasing of a construction project in which both the principal and accessory structures are to be built simultaneously.
- (vii) In residential districts, total area of accessory building(s) or structure(s) with a roof shall not exceed 70 percent of the area of the principal building. The maximum square footage for accessory and principal buildings are also subject to the defined maximum building lot coverage requirements and maximum floor area ratios defined by the ordinance.
- (viii) In residential districts, the building or structure shall not exceed the height of the principal building or structure and in no case exceed 18 feet in height from the highest point of the building or structure to the finished floor.

14-213 (8) (c)

(c) **Standards for Variances.** The board shall not grant a variance unless it makes findings based upon evidence presented to it as follows:

(i) The particular physical surroundings, shape, topographic conditions of the specific property involved that would result in a particular hardship upon the owner as distinguished from a mere inconvenience, if the strict application of this ordinance were carried out must be stated;

(ii) The conditions upon which the petition for a variance is based would not be applicable, generally, to other property within the same district;

(iii) The variance will not authorize activities in a zone district other than those permitted by this ordinance;

(iv) Financial returns only shall not be considered as a basis for granting a variance;

(v) The alleged difficulty or hardship has not been created by any person having an interest in the property after the effective date of this ordinance;

(vi) That granting the variance requested will not confer on the applicant any special privilege that is denied by this ordinance to other lands, structures, or buildings in the same districts;

(vii) The variance is the minimum variance that will make possible the reasonable use of the land, building, or structure;

(viii) The granting of the variance will not be detrimental to the public welfare or injurious to other property or improvements in the area in which the property is located; and

(ix) The proposed variance will not impair an adequate supply of light and air to adjacent property, substantially increase the congestion in the public streets, increase the danger of fire, endanger the public safety, or substantially diminish or impair property values within the area.

(d) Non-conformity does not constitute grounds for granting of a variance. No non-conforming use of neighboring lands, structures, or buildings in the same district, and no permitted or nonconforming use of lands, structures, or buildings in other districts shall be considered grounds for the issuance of a variance.

(e) Prohibition of use variances. Under no circumstances shall the board of appeals grant a variance to allow a use not permissible under the terms of this ordinance in the district involved, or any use expressly or by implication prohibited by the terms of this ordinance in said district.

(f) Conditions and restrictions by the board. The board may impose such conditions and restrictions upon the premises benefitted by a variance as may be necessary to comply with the provisions set out in

§ 14-213(8)(c) above to reduce or minimize the injurious effect to such variation upon surrounding property and better carry out the general intent of this ordinance. The board may establish expiration dates as a condition or as a part of the variances





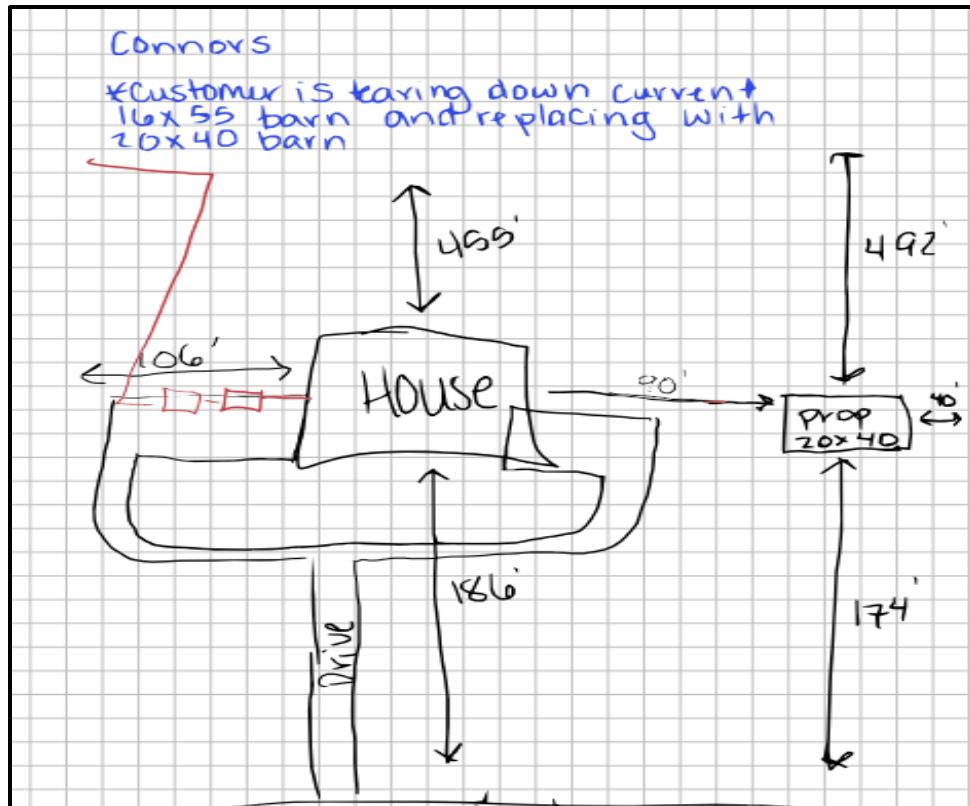

ITEM#2 Boom Sign and Lighting: Requests electronic signage variance for a proposed Jubilee Hills sign on Conference Drive. The 0.98- acre property referenced as Davidson County Tax Map/Parcel# 02600017100 Zoning Ordinance Sections: 14-305 (1) (c) Property Owner: A.P. Development Properties, INC

AGENDA ITEM REVIEW PROCESS:

- Staff Presentation
- Applicant Presentation
- Public Hearing Public Comments
- Board Discussion and Motion

STAFF NOTES:

The proposal is for a pole sign including two (2) signage areas with a total of sixty-three (63 sq.ft.) square feet. The proposal is for the entire area of the fifty-eight (58 sq. ft.) square feet primary section of the pole sign to be an electronic message board changeable copy sign. The City's Sign Ordinance limits changeable copy signs to a maximum fifty (50%) percent of the pole signage area. The permitted total square footage of the electronic changeable copy message board would be thirty-one and a half (31.5 sq. ft.) square feet. The Sign Ordinance

requires a static regular sign section with a changeable copy message board signage proposal.

MOTION OPTIONS:

1. Motion to approve the Sign Ordinance section variance request based on the request meeting the variance review criteria 14-305 (7)(b) (vi) since the requested variance will not be detrimental to the public welfare, injurious to other property, or to the intent and spirit of this chapter.
2. Motion to deny the variance request based on the request not meeting the Sign Ordinance section variance review criteria as determined by the Board during the meeting
3. Motion to defer the request for the applicant to provide additional information as determined by the Board during the meeting

*Staff recommendation to be provided during meeting

Referenced Sign Ordinance Sections:

14-305 (2)(c)(iv)

(c) Pole or ground signs are permitted subject to the following standards:

(i) A use shall be permitted to have one ground or pole sign for each street frontage. In the event a street frontage is in excess of 250 feet in length, one additional such sign shall be permitted with a minimum separation of 100 feet between the signs.

(ii) Such sign shall have a maximum display surface area of 50 square feet.

(iii) The maximum height of a ground sign shall be four feet. Ground signs which are integrated into an attractive brick, stone, or wood architectural feature or an earth berm, all of which shall be permanently landscaped, may exceed four feet in height to a maximum of seven feet.

(iv) The maximum area of a pole sign including no more than two signs shall be 70 square feet total and the maximum area of a ground sign including no more than two signs shall be 50 square feet total. ***Any changeable copy sign shall be limited to no more than 50 percent of the total sign square footage.***

14-305 (7)(b)(c)(d)

(7) Standards for appeal decisions. Before granting any relief from the application of the provisions of this, the board shall make specific findings of fact justifying the case under appeal.

(a) For a finding of error, the board shall state the section of the ordinance that is being appealed and how the enforcing officer erred in the application of the ordinance requirements.

(b) For an action granting a variance, the board shall state the provisions being varied and shall grant the minimum variance to satisfy the relief of hardship, and shall state the specific hardship which justifies the variance.

The board shall not grant a variance unless it makes findings based upon evidence presented to it as follows:

(i) The particular physical surroundings, shape, or topographic conditions of the specific property involved that would result in an exceptional hardship upon the owner as distinguished from an inconvenience.

(ii) The conditions upon which the petition for a variance is based would not be applicable to other similarly situated properties.

(iii) The hardship has not been created by any person having an interest in the property.

(iv) Financial returns only shall not be considered as a basis for granting the variance.

(v) The variance will not be detrimental to the public welfare, injurious to other property, or to the intent and spirit of this chapter.

(vi) The variance does not confer a special privilege to the applicant that is denied to others.

(c) Under no circumstances shall the board grant a variance to allow a sign which is not permitted by this chapter.

(d) The board may impose such conditions and restrictions upon the premises benefitted by the variance as may be necessary to reduce or minimize any injurious effect upon adjoining uses or property, and to better carry out the general intent of this chapter.



**Jubilee Hill Senior Living
Courtyard By Marriott
REV#1- EMC**

5'x10' Double Sided EMC
10' from grade to bottom of sign
(2) ACM Panels with Jubilee Hills Logo mounted



50'

Find us on and on our website: www.husksigns.com

Jubilee Hill Senior Living
322 Northcreek Blvd, Goodlettsville, TN 37072

Courtyard by Marriott Nashville Goodlettsville
865 Conference Dr, Goodlettsville, TN 37072



<p>1115 Indy Court Evansville, IN 47725 Phone: 1-800-999-4140 1-800-874-4726 Fax: 812-873-0981</p>	Project Name: Jubilee Hill Senior Living	Sales Person: Kip	<p>This image is exclusive property of Husk Companies, Inc. It may not be copied, reproduced, copied, displayed or published in any form without the express written permission of Husk Companies, Inc. All rights reserved. No negative damages will be awarded for violations. By viewing this document, I have acknowledged you electronically and I am bound by the terms and conditions of the license agreement and restrictions.</p> <p>All Rights Reserved Copyright 2014 Husk Companies, Inc.</p>
	Location: Nashville	Designer: Christine	
ACCEPTED BY:	Date of Booking: 1-27-2024	Revisions: 01	
ACCEPTED DATE:			

TO APPROVE THIS ARTWORK, PLEASE SIGN AND DATE THE APPROPRIATE PAGE(S) WHERE INDICATED AND RETURN TO HUSK SIGNS.

**WILL NEED ARTWORK
and raceway color**

**Jubilee Hills
REV#2- Channel Letters Option 3**

Internally Illuminated channel letters mounted to raceway
Over all 14' x 20.5'

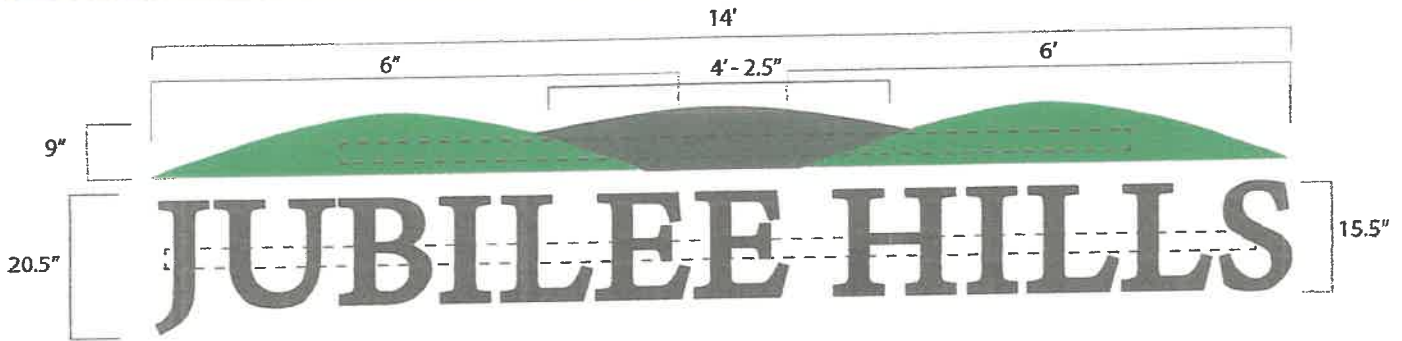

Find us on  and on our website: www.huskysigns.com



1115 Indy Court
Evansville, IN 47715
Phone: 1-800-909-HUSK
Local: 812-473-7000
Fax: 812-867-0848

Project Name: Jubilee Hills
Location: 322 North Creek Blvd
Goodlettsville Tn.
ACCEPTED BY:
ACCEPTED DATE:

Sales Person: Kip
Designer: Cheyanne
Date of Drawing: 2-14-24
Revision: #2

This design is exclusive property of Husk Companies, Inc. It may not be used, reproduced, copied, displayed or exhibited in any fashion whatsoever without the written permission of Husk Companies, Inc. Legal action for any punitive damages will be considered for violation. By receiving this document, it is understood you acknowledge and agree to the above-stated terms and restrictions.

All Rights Reserved Copyright 2014 HUSK COMPANIES, INC.

TO APPROVE THIS ARTWORK, PLEASE SIGN AND DATE THE APPROPRIATE PAGE(S) WHERE INDICATED AND RETURN TO HUSK SIGNS.

Fee _____
 Date _____
 Sign District _____

Permit No. _____
 Map _____
 Parcel No. _____
 Zoning _____
 County _____

Application For Sign Permit

CITY OF GOODLETTSVILLE, TENNESSEE

Dooms:signpermitting@gmail.com
 Guy Dearmon

JOB ADDRESS		322 North Creek Blvd.	
1. OCCUPANT			
Subilee Hill's			
2. OWNER	MAIL ADDRESS	ZIP	PHONE
Subilee Hill's	322 North Creek Blvd	37072	
3. CONTRACTOR	MAIL ADDRESS	PHONE	LICENSE NO.
Boom Sign & Lighting	189 Sharp Springs Rd	615-255-5511	
4. ARCHITECT OR DESIGNER	MAIL ADDRESS	PHONE	LICENSE NO.
Musk Sign's	115 Lady Court	812-473-2000 Ext 131	
5. WORDING			
Subilee Hill's			
6. TYPE ILLUMINATION (FLASHING PROHIBITED)		TYPE PERMANENT SIGN	
		TEMPORARY	
7. PROJECTING	WALL	SINGLE FACE	MARQUEE
GROUND	POLE	DOUBLE FACE	OTHER
8. ESTIMATE OF VALUATION OF WORK		EXISTING SIGNS	
APPROVAL	FOOTING	FINAL	ISSUED BY
SPECIAL CONDITIONS			

JOB ADDRESS
OWNER

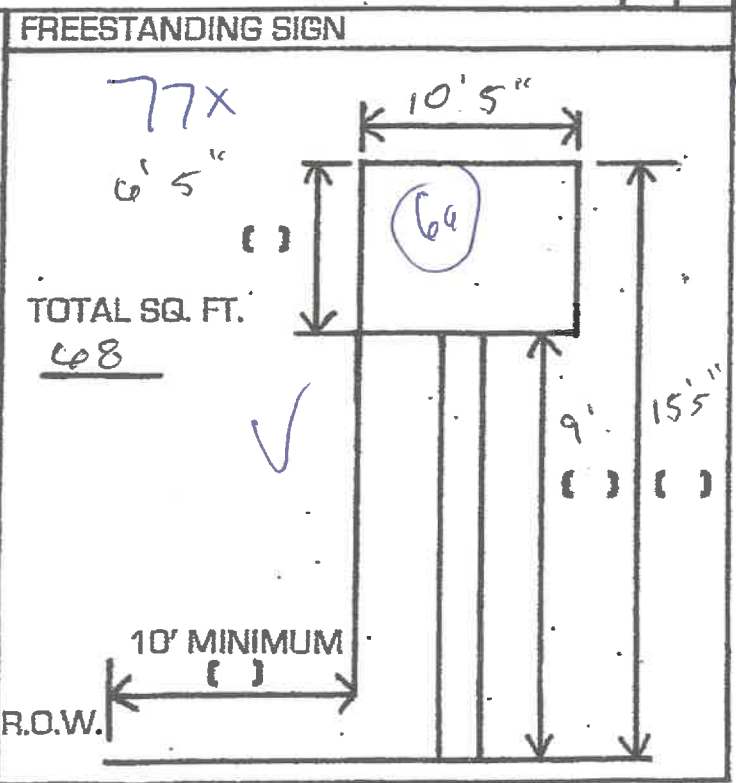
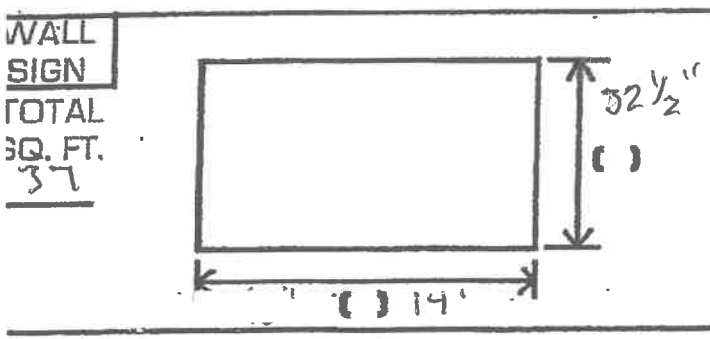

NOTICE

IF PERMIT BECOMES NULL AND VOID IF WORK ON CONSTRUCTION THORIZED IS NOT COMMENCED WITHIN 3 MONTHS.

HEREBY CERTIFY THAT I HAVE READ AND EXAMINED THIS PPLICATION AND KNOW THE SAME TO BE TRUE AND CORRECT ALL DIVISIONS OF LAWS AND ORDINANCES GOVERNING THIS TYPE OF WORK WILL BE COMPLIED WITH WHETHER SPECIFIED HEREIN OR THE GRANTING OF A PERMIT DOES NOT PRESUME TO GIVE AUTHORITY TO VIOLATE OR CANCEL THE PROVISIONS OF ANY OTHER LOCAL LAW REGULATING CONSTRUCTION OR THE PRACTICE OF CONSTRUCTION.

CONTRACTOR OR AUTHORIZED AGENT _____ DATE _____

OWNER/BUILDER _____ DATE _____